

TWIN SCREW PUMP

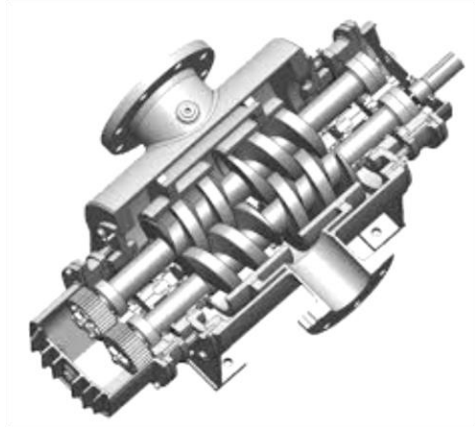

Features:-

Capable of Higher capacity / Bulk Liquid Handling

No metal to metal contact between rotors

Long life in service

Dry running capability

Lowest NPSHR

Low Noise & Vibration

Mounting type- Horizontal Foot, Horizontal Flanges, Vertical pedestal

MOC-Cast Iron, Cast Steel, Fabricated Carbon Steel, Stainless Steel & etc.,

Sealing - Gland Packing, Grafoil Packing , Mechanical seal

Application:-

Loading / unloading of Lube Oil , Fuel oil and any industrial liquids

Railway wagon , Truck tankers, Ships and Tankers-Bulk cargo handling.

Lubrication, circulation and cooling.

Process pumping of high viscous products, bitumen, molasses, soap and similar products.

Long distance pipeline pumping of viscous products



Application:-

Loading / unloading of Lube Oil , Fuel oil and any industrial liquids
 Railway wagon , Truck tankers, Ships and Tankers-Bulk cargo handling.
 Lubrication, circulation and cooling.
 Process pumping of high viscous products, bitumen, molasses, soap and similar products.
 Long distance pipeline pumping of viscous products

Operating Ranges

Capacity	10,000 LPM
Working Pressure	~ 24 bar
Working Temperature	+ 380 Degree
Pump Speed	~ 2500 RPM
Application	Lube Oil , LDO, HSD, Furnace Oil, Bitumen , Molasses , Veg Oil , Grease , Additives, Paraffin, Base oils and any high viscosity industrial liquids.

Industrial

Power Plants	Steel Plants	Cement Plants	Fertilizer Plants	Ship Building
Oil & Gas	Petroleum Refinery	Food Industries	Chemical Plants	Bulk Liquid handing Plants
Sugar Plants	Paint Industries	Paper Mills	Bio-Diesel Industry	Lube Oil Blending / Grease Making Plants
Rubber Industries	Polymer Industries	Storage Terminals		



No.16 /29, Jani Basha Street , Royapettah, Chennai-600 014

Mobile No : 8608860007, 9941423185

sgcpumps@gmail.com

www.sgcpumps.com